

CARRI PORTABLOCCHI

I Carri portablocchi standard su rotaia disponibili in varie versioni per rispondere a tutte le esigenze.

GB Standard block carriages on railway for any use.

F Chariots porteblocs standard sur rail disponibles en differentes versions pour repondre a toutes les exjences

E Carros porta bloques standard sobre vias disponibles en varias versiones para responder a todos las exigencias

D Standard Block Wagen auf Schiene, disponibel in versch. Ausführungen, für jegliche Anwendung

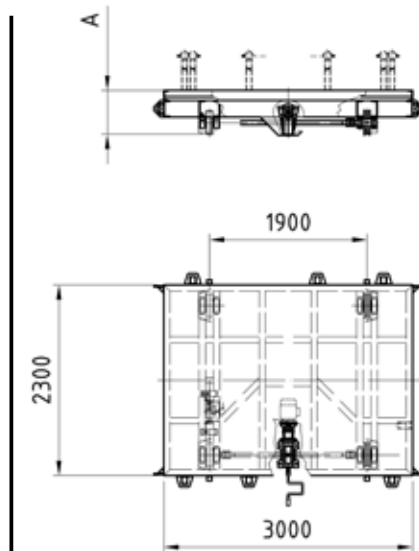

CM-CMP

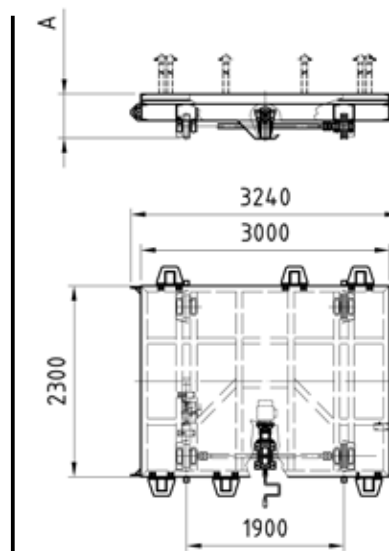

CMP PW

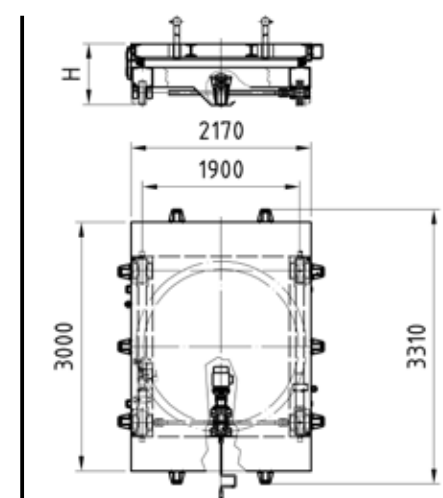

CMR-CMPR/E

	CM	CMP	CMR	CMPR	CMPRE	CMP PW*	CMPRE J
PORTATA / CAPACITY CAPACITE' / CAPACIDAD / TRAGLAST ton.	40-60	40-60	40-60	40-60	40-60	40-60	40-60
PIANO FISSO / FIXED TABLE PLAN FIXE / MEJA FISSA / FESTER TISCH	✓	✓	-	-	-	✓	-
ROTAZIONE MANUALE / MANUAL ROTATION ROTATION MANUELLE / ROTACION MANUAL MANUELL ROTIERBAR	-	-	✓	✓	-	-	-
ROTAZIONE ELETTRICA / ELETTRIC ROTATION ROTATION ELECTRIQUE / ROTACION ELECTRICA ELEKTR. TORIERBAR	-	-	-	-	✓	-	✓
PRECISIONE / PRECISION PRECISION / PRECISION / PRÄZISION	-	+	-	+	+	+	++

* Versione rinforzata per POLIWIRE / Version for POLIWIRE / Version renforcee pour POLIWIRE / Version por POLIWIRE / POLIWIRE Version
J Versioni per DF PLUS/JOLLY / Version for DF PLUS/JOLLY / Version pour DF PLUS/JOLLY / Version por DF PLUS/JOLLY / DF PLUS/JOLLY Version

ton.	40	60
A (mm)	528	620
H (mm)	734	820

A richiesta portate e versioni fuori standard / On demand capacity and version not standard / A la demande capacité et versions pas standard
Su pregunta capacidades y versiones non standard / Ausser Standard Traglast und Ausführung auf Anfrage

